



PO BOX 1190 - 40 LAMPLIGHTER ST. - OAK HILL, WV 25901
PHONE: (304) 465-3295 / FAX: (304) 465-8576

WWW.HIGHLAND-IND.COM

PROUDLY SERVING THE UNDERGROUND MINING
INDUSTRY'S EQUIPMENT NEEDS FOR OVER 30 YEARS

BELT FEEDER / TAILPIECE COMBINATION
FOR SHORT PANELS OR MAINLINE.

OUR 'RAPID MOVE' DRAG FEEDER

STANDARD FEATURES:

- DESIGNED FOR 24", 36", 42", OR 48" BELTS
(915MM, 1065MM, & 1220MM)
- ELIMINATES THE TAILPIECE
- BELT MOVES MADE QUICK & EASY
- VERY LITTLE MAINTENANCE OR DOWNTIME
- CONVEYOR DRIVEN BY EXISTING BELT
- ELIMINATES ELECTRIC MOTOR ON MACHINES
UP TO 320 TONS PER HOUR
- THREE-WAY DUMPING
- UNLOADING TIME OF 7 1/2 TON CAR:
APPROXIMATELY 24 SECONDS
- MOVES TAILPIECE AND FEEDER IN ONE
QUICK MOVE



OPTIONS AVAILABLE:

20HP TO 75HP (15.5KW
TO 55KW) ELECTRIC
MOTOR FOR CONVEYOR
(DETERMINED BY TONS
PER HOUR)

- WITH OR WITHOUT PICK
BREAKER

CUSTOM MODIFICATIONS
CAN BE MADE TO
MEET MINE
APPLICATIONS



OPTIONAL ELECTRIC MOTOR
FOR CONVEYOR



BELT DRIVEN CONVEYOR

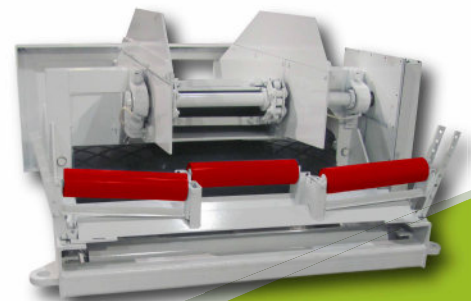

INTERGRADED TAILPIECE



HEAVY DUTY TAIL SECTION
DUMP GUARD

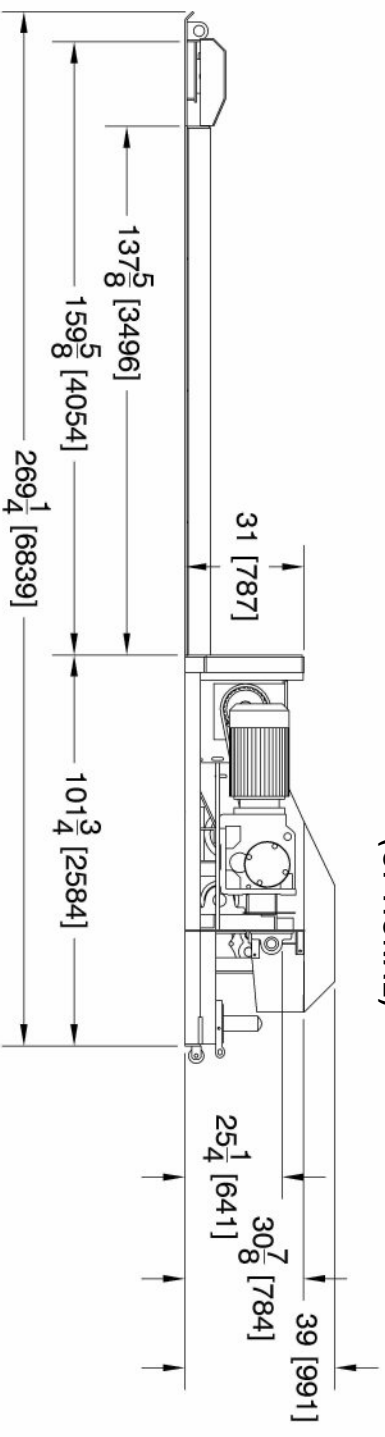
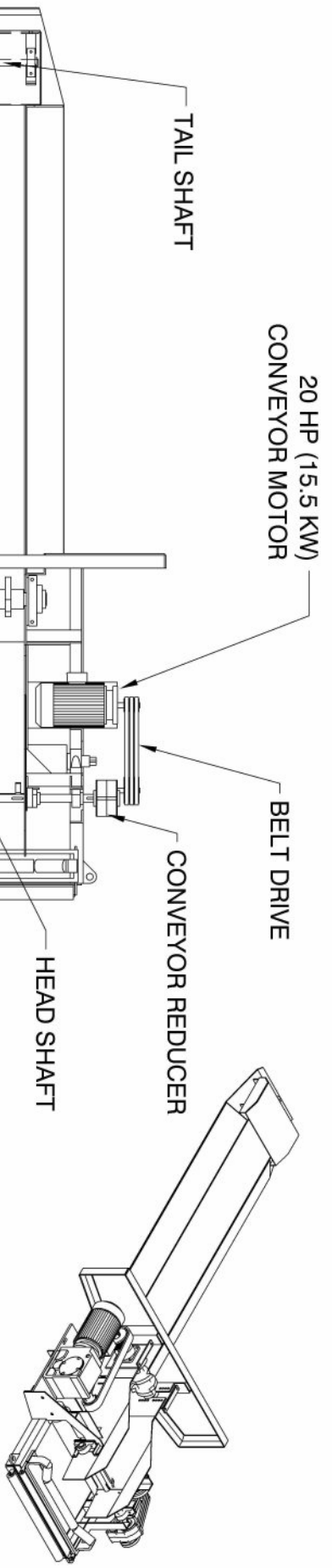

'RAPID MOVE' DRAG FEEDER

