



PO BOX 1190 - 40 LAMPLIGHTER ST. - OAK HILL, WV 25901
 PHONE: (304) 465-3295 / FAX: (304) 465-8576

WWW.HIGHLAND-IND.COM

PROUDLY SERVING THE UNDERGROUND MINING
 INDUSTRY'S EQUIPMENT NEEDS FOR OVER 27 YEARS

10/21K SHUTTLE CAR

RUGGED 10SC COMPONENTS, LOW 21SC LOADING HEIGHT FOR 48"+ SEAMS

VARIABLE FREQUENCY DRIVE 480/575/950 VAC OR 600 VDC

GENERAL INFORMATION:

- 30" LOAD END HEIGHT
- CONVEYOR WIDTHS FROM 40" TO 64" (1016-1625MM)
- LARGE 25,000 LBS PAY LOAD
- TRAM SPEED: UP TO 5.7 MPH (9.17KPH)
- STANDARD CONVEYOR CHAIN: 4.1 PITCH (104.1MM)
- VARIABLE SPEED CONVEYOR CHAIN 0-100 FPM
- FOUR WHEEL DRIVE, INTERCHANGEABLE PLANETARY WHEEL UNITS
- MULTI-WET DISC SERVICE & PARK BRAKE SYSTEM
- DRY CHEMICAL FIRE SUPPRESSION SYSTEM
- APPROVED OPERATOR'S CANOPY
- 25HP (19KW) PUMP MOTOR
- POWERED BY VFD CONTROLS WITH
- 440/575/950 VAC OR 600 VDC INPUT
- VFD PUMP CONTROL FOR SMOOTH START-UP OF PUMP
- VFD CONVEYOR CONTROL FOR SMOOTH VARIABLE SPEED CONVEYOR CHAIN OPERATION
- 75HP (55KW) TRACTION MOTORS (HIGH TORQUE, SMOOTH OPERATION)
- OPTIONAL 115HP (85KW) TRACTION MOTORS
- MSHA APPROVAL FOR UP TO 850' (259M) OF CABLE ON DC CABLE

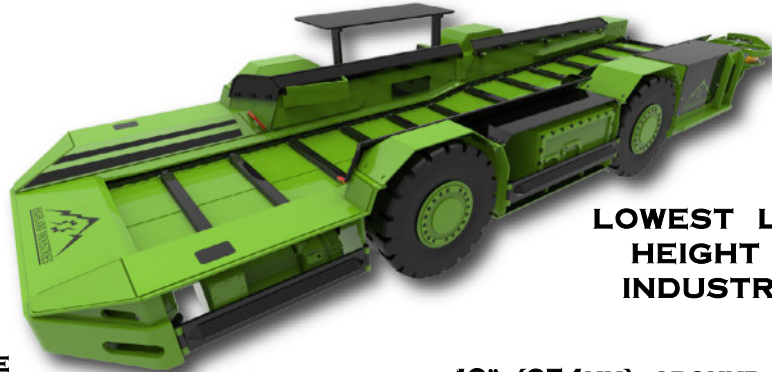

LOWEST LOAD END HEIGHT IN THE INDUSTRY (30")

- 10" (254MM) GROUND CLEARANCE
- 12 1/2" (318MM) BOOM CLEARANCE
- 42" - 56" (1067-1422MM) CANOPY HEIGHT
- MAIN FRAME HEIGHT 37" (940MM) (WITHOUT SIDE BOARDS)

CUSTOM MODIFICATIONS CAN BE MADE TO MEET MINE APPLICATIONS

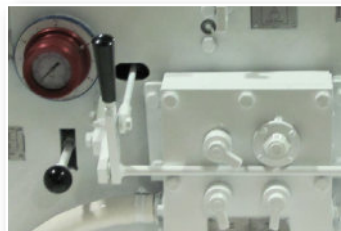

CHECK ALL HYDRAULIC PRESSURES FROM ONE CONVENIENT LOCATION



OPTIONAL CAMERA SYSTEMS AND PROXIMITY SYSTEMS



OPTIONAL DUAL CONVEYOR LOADER CHAIN



**SAMINCO VFD CONTROL PANEL
 480/575/950 VAC OR 600 VDC**



SIT UP OR LIE DOWN OPERATORS DECK

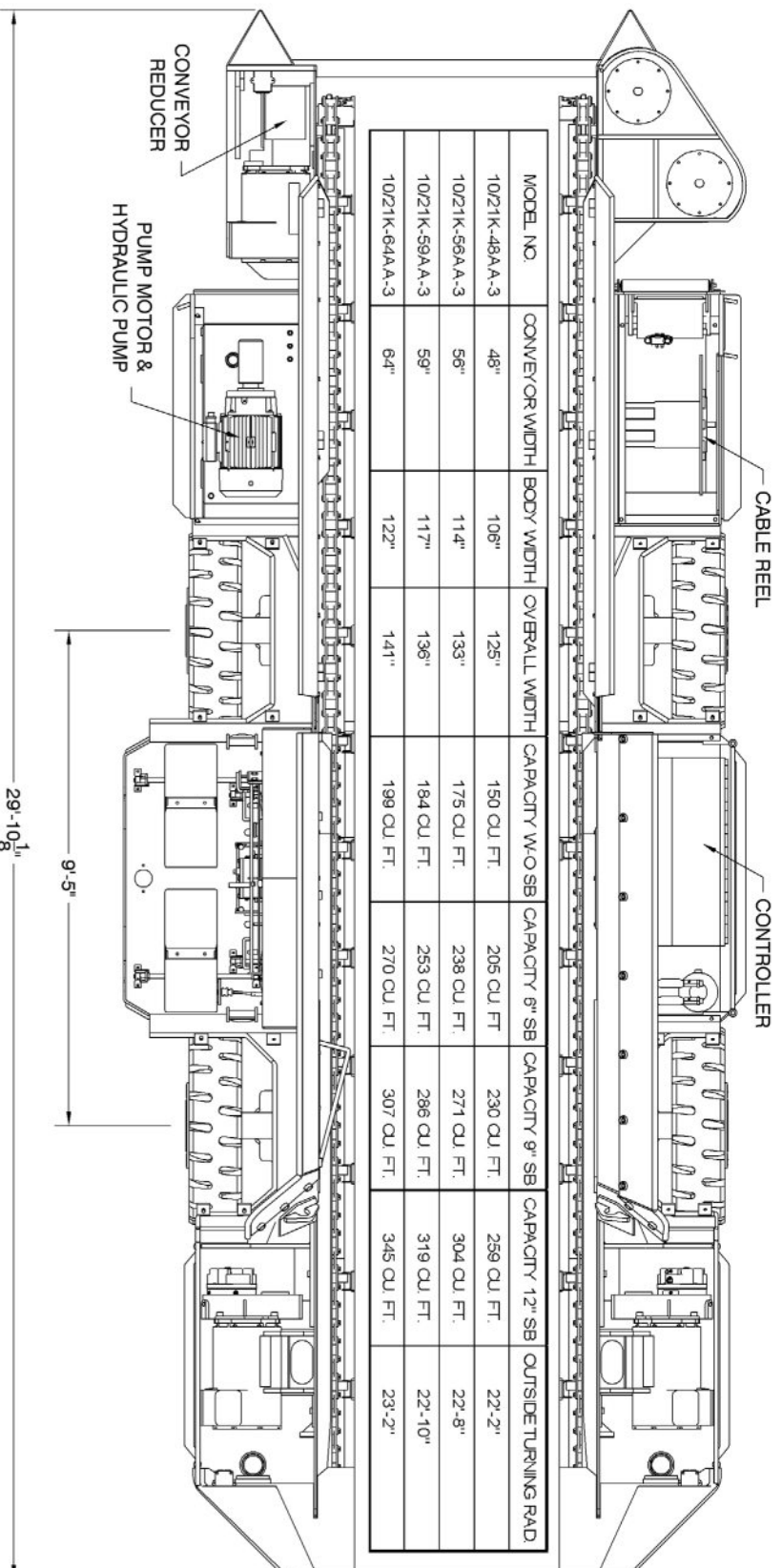

MODEL NO.	CONVEYOR WIDTH	BODY WIDTH	OVERALL WIDTH	CAPACITY W.O SB	CAPACITY 8" SB	CAPACITY 9" SB	CAPACITY 12" SB	OUTSIDE TURNING RAD.
10/21K-48AA-3	48"	106"	125"	150 CU. FT.	205 CU. FT.	230 CU. FT.	259 CU. FT.	22'-2"
10/21K-56AA-3	56"	114"	133"	175 CU. FT.	238 CU. FT.	271 CU. FT.	304 CU. FT.	22'-8"
10/21K-59AA-3	59"	117"	136"	184 CU. FT.	253 CU. FT.	286 CU. FT.	319 CU. FT.	22'-10"
10/21K-64AA-3	64"	122"	141"	199 CU. FT.	270 CU. FT.	307 CU. FT.	345 CU. FT.	23'-2"

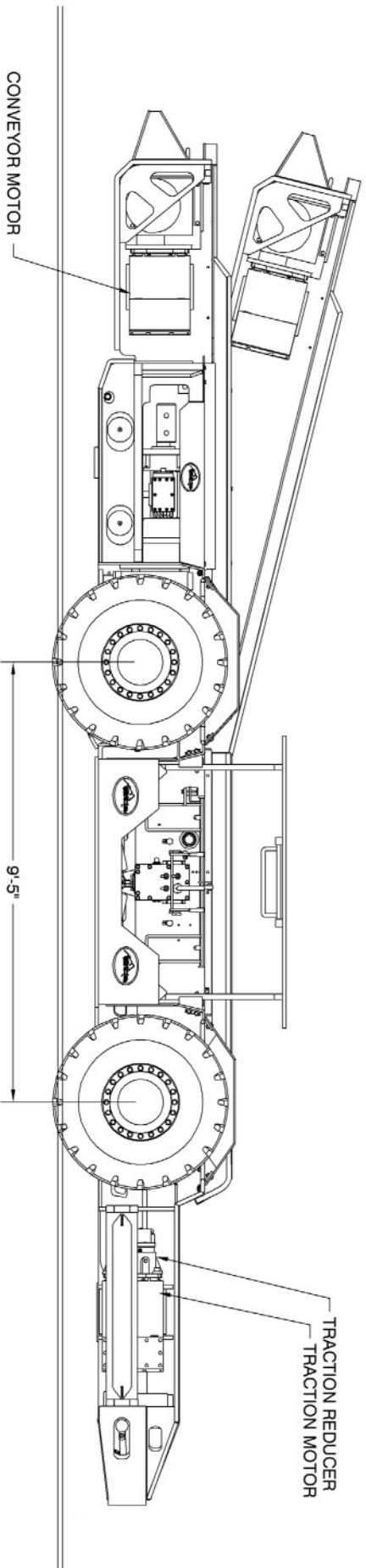

10/21K SHUTTLE CAR