



PO BOX 1190 - 40 LAMPLIGHTER ST. - OAK HILL, WV 25901
 PHONE: (304) 465-3295 / FAX: (304) 465-8576

WWW.HIGHLAND-IND.COM

PROUDLY SERVING THE UNDERGROUND MINING
 INDUSTRY'S EQUIPMENT NEEDS FOR OVER 30 YEARS

10/21B SUPER CAPACITY SHUTTLE CAR

VARIABLE FREQUENCY DRIVE 480 / 575 / 950VAC or 600VDC

GENERAL INFORMATION:

- CONVEYOR WIDTHS FROM 40" TO 64" (1016-1625MM)
- HAULING CAPACITY FROM 30,000 TO 45,000
- TRAM SPEED: UPTO 5.7 MPH (9.17KPH)
- STANDARD CONVEYOR CHAIN: 4.1 PITCH (104.1MM) 125,000LBS (55.895KG)
- VFD CONVEYOR CONTROL FOR SMOOTH VARIABLE SPEED CONVEYOR CHAIN OPERATION
- FOUR WHEEL DRIVE, INTERCHANGABLE PLANETARY WHEEL UNITS
- MULTI-DISC WET SERVICE & PARK BRAKE SYSTEM
- DRY CHEMICAL FIRE SUPPRESSION SYSTEM
- APPROVED OPERATOR'S CANOPY



CUSTOM MODIFICATIONS CAN BE MADE TO MEET MINE APPLICATIONS



SCR OR IGBT CONTROL PANEL



(VARIABLE FREQUENCY DRIVE) CONTROL PANEL
 480/ 575 / 950 VAC - 600 VDC

HIGHLAND OFFERS THE LATEST UPDATES FOR YOUR MACHINE SUCH AS:



OPTIONAL SERVICE JACKS

VFD CONTROLLER WITH:

- VARIABLE SPEED CONTROLLER
- SMOOTH START-UP OF PUMP
- 115HP (85KW) AC TRAM MOTORS (HIGH TORQUE, SMOOTH OPERATION)
- SERVICE JACKS
- CAM STYLE SPOOLING DEVICES
- 25HP (19KW) PUMP MOTORS
- 1 PIECE CASTED PIVOT AXLES
- DUAL LOADER CHAIN
- INDEPENDENT SUSPENSION
- LED LIGHTS
- CAMERA SYSTEMS
- PROXIMITY SYSTEM



CHECK ALL HYDRAULIC PRESSURES FROM ONE CONVENIENT LOCATION



4.1 PITCH CONVEYOR CHAIN OR OPTIONAL DUAL LOADER CONVEYOR CHAIN



OPTIONAL LED LIGHTS, CAMERA SYSTEMS AND PROXIMITY SYSTEMS

FRAME HAS 2 YEAR WARRANTY!

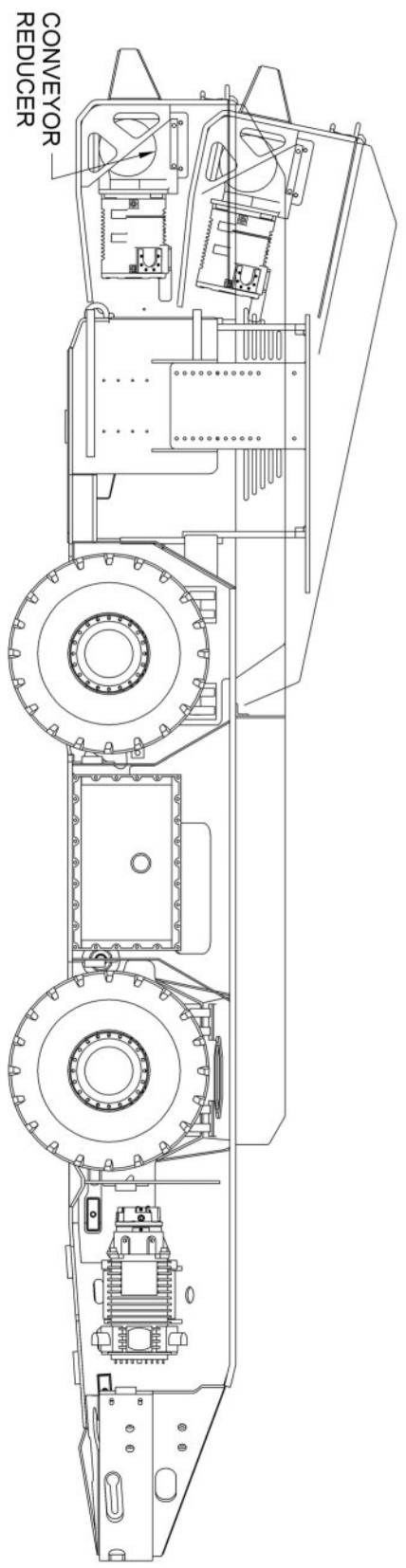
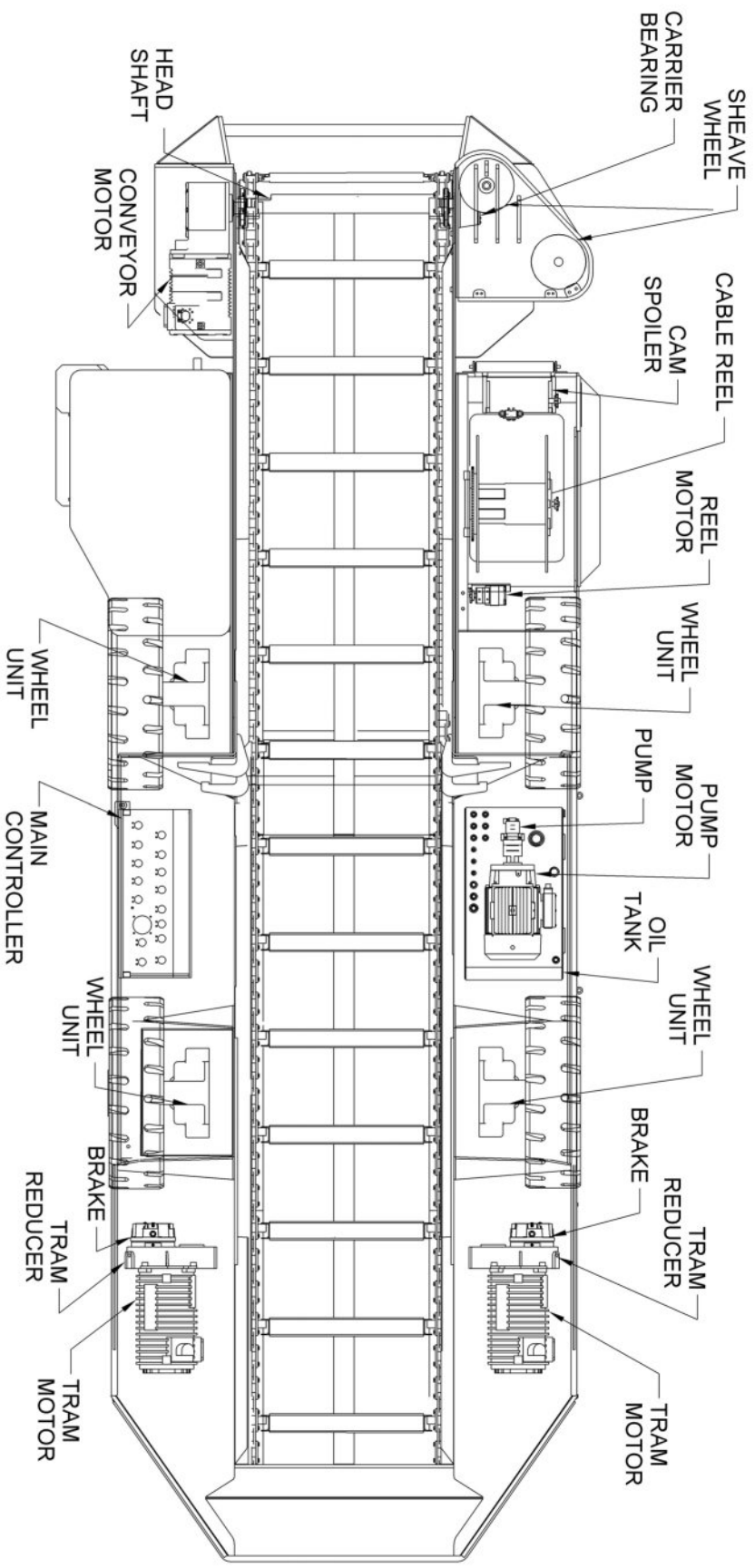

10/21 HB SUPER CAPACITY SHUTTLE CAR